

## TECHNICAL DATA SHEET



# KRASO® System Cover KDS 150

### Product image



### Product information

Item	<b>KRASO®</b> System Cover KDS 150 – heat-shrink technology – 7-times
Water pressure tightness (bar)	1,5
Weight (kg)	0,65
Item No.	KKDS150SDWS7

### Technical drawing

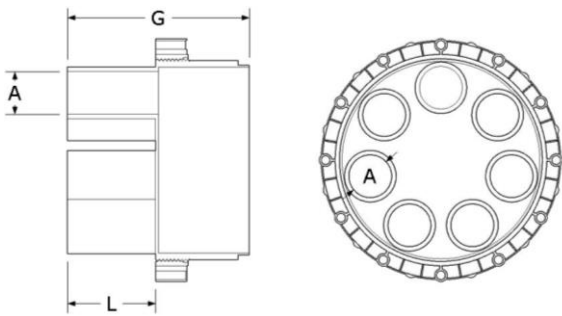

### Dimensions

A   Application area (mm)	7 × 13 – 33
L   Socket length (mm)	70
G   Total length (mm)	146

### Application area

with factory-made, water pressure tight cover, simple opening by knocking off before installation (on site), incl. bayonet fitting with unit nut and anti-twist lock (prevents unintentional opening), with 7 adapters for installation of pipes or cables, incl. heat-shrink hose (length approx. 20 cm) for use with heat-shrink technology

### Material

System cover	ABS
Union nut	ABS

### Tests

MPA	yes
DVGW	-

### Resistances

Temperature	-20°C to 90°C
-------------	---------------